



# CORDLESS TILLER + CULTIVATOR

48V MAX\* | 2.0 Ah | 14-INCH

## OPERATOR'S MANUAL

A Division of Snow Joe®, LLC

Model 24V-X2-TLR14

Form No. SJ-24V-X2-TLR14-880E-MR1

## IMPORTANT! Safety Instructions

### All Operators Must Read These Instructions Before Use

Always follow these safety guidelines. Failure to do so may result in serious bodily injury or death.

### General Safety WARNINGS!

Before using this cordless tool, carefully read and observe the safety rules and instructions listed below. Before starting work, make sure that you know how to stop the machine in case of an emergency. The incorrect use of this machine could cause serious injury. Keep these instructions in a safe place and on hand so that they can be consulted when required.

Notice the personal safety alert symbol  used in this manual to draw your attention to a WARNING given along with the particular operating instruction. This means that the operation requires special ATTENTION, CAUTION, and AWARENESS.

- 1. Keep work area clean and well-lit** – Cluttered, dark areas invite accidents.
- 2. Replacement parts** – When servicing this unit, use only identical replacement parts. Replace or repair damaged parts immediately.
- 3. Keep children, bystanders, and pets away** – All spectators, including pets, should be kept a safe distance away from the work area.
- 4. Know your product** – Know how to start and stop the machine. Be thoroughly familiar with the controls.
- 5. Use the right tool** – Do not use this machine for any job except that for which it was intended.
- 6. Dress properly** – Do not wear loose clothing or jewelry as such articles can become caught in moving parts. Wear a protective covering to contain long hair. Wearing rubber gloves and substantial non-slip footwear is recommended when working outdoors.
- 7. Avoid accidental starting** – Do not carry the garden tiller + cultivator with your finger on the switch.

 **CAUTION!** Moving parts will continue to run for several seconds after turning off the machine.

- 8. Moving parts** – Keep hands and feet away from moving parts. Keep guards in place and in proper working order.
- 9. Do not force the tool** – It will perform better with less likelihood of personal or mechanical injury if it is used at the rate for which it was designed.
- 10. Do not overreach** – Keep proper footing and balance at all times.

If the tiller + cultivator strikes a foreign object, follow these steps:

- **Stop the cordless tiller + cultivator.**
  - **Inspect for damage.**
  - **Repair any damage before restarting and operating the tool.**
- 11. Use safety glasses** – Also use safety footwear, snug-fitting clothing, protective gloves, hearing, and head protection.
  - 12. Remove the batteries** – Remove the batteries from the tiller + cultivator when it is not in use, before servicing it, when changing accessories, and when performing any other maintenance task.
  - 13. Store idle tool indoors** – When not in use, the tiller + cultivator should be stored indoors in a dry and high or locked-up place out of the reach of children.
  - 14. Maintain the tiller + cultivator with care** – Keep the cutting edges sharp and clean for optimal performance and to reduce the risk of injury. Keep the handles dry, clean, and free from oil and grease. Follow the additional recommendations described in the maintenance section of this manual.
  - 15. Avoid dangerous environments** – Do not use the tiller + cultivator in rain or in damp or wet locations. Do not operate the tiller + cultivator in gaseous or explosive atmospheres or use the tiller + cultivator near flammable or combustible liquids. Motors in these tools normally spark, and the sparks might ignite fumes.
  - 16. Stay alert** – Watch what you are doing. Use common sense. Do not operate the tiller + cultivator when you are tired or under the influence of drugs, alcohol, or other medication.

- 17. Check for damaged parts** – Before further use of the appliance, a guard or other part that is damaged should be carefully checked to determine that it will operate properly and perform its intended function. Check for alignment of moving parts, binding of moving parts, breakage of parts, mounting, and any other condition that may affect its operation. A guard or other part that is damaged should be properly repaired or replaced. Contact the Snow Joe® + Sun Joe® customer service center at 1-866-SNOWJOE (1-866-766-9563) for assistance.

## Training

- Read, understand, and follow all instructions on the tiller + cultivator and in the manual before operating this unit. Thoroughly familiarize yourself with the controls and the proper use of the equipment. Know how to stop the unit and disengage the controls quickly.
- Children should never be allowed access to the equipment. Adults should never operate the equipment without carefully reading and understanding these instructions.
- Keep the area of operation clear of all persons, particularly small children or pets.
- Exercise caution to avoid slipping or falling.
- Always plan your cultivating path to avoid discharge of material toward people, pets, and property (e.g. windows, cars, etc.). Thrown objects can cause serious personal injury and property damage. Do not allow anyone in front of a running machine.
- Keep people, pets, and property at least 25 feet from the tiller + cultivator while it is in operation. Stop the tiller + cultivator if people or pets enter the discharge area.
- Always observe the surface conditions in order to avoid slipping, falling, and unexpected objects.

## Preparation

- Always inspect the area where the tiller + cultivator is to be used. Remove all objects (i.e. stones, sticks, wires, and other foreign materials) that could be thrown by the blades or cause the operator to trip.
- Thrown objects can cause serious injury to the eyes and exposed body. Always wear safety glasses or eye shields during operation and while making an adjustment or repair.
- Always operate the tiller + cultivator wearing adequate garments. Do not wear jewelry or other loose clothing, which could become entangled in moving parts. Wear non-slip footwear to ensure proper footing.
- Observe any noise-prevention regulations and laws.
- Inspect the tiller + cultivator for worn, missing, or damaged parts and safety labels. See maintenance section for detailed instructions.

## Operation

- Do not operate the machine while under the influence of alcohol or drugs.
- Keep all safety devices in place and in proper working order. Do not operate with missing or damaged components.
- Ensure the controls (start/stop) function properly before cultivating.
- Hold onto the tiller + cultivator with both hands during operation. Ensure the grips are dry.
- Contact with rotating parts can amputate hands and feet. Keep hands and feet away from all rotating parts.
- Only operate the tiller + cultivator when there is good visibility or light and dry conditions. Always watch your footing and keep a firm hold on the grips. Walk; don't run!
- Do not operate the tiller + cultivator on slippery surfaces. Check your footing during use.
- Exercise caution when changing direction and operating the tool on slopes. Always keep feet and legs a safe distance away from the machine. Look for hidden obstacles or hazards.
- Do not overload machine capacity by attempting to cultivate too deeply. It will cause excessive resistance.
- Stop the tiller + cultivator and remove the batteries before leaving the operating position (behind the handles) to adjust or inspect the unit. Wait until the blades have come to a complete stop.
- If the tiller + cultivator should start to vibrate abnormally, stop the machine and inspect thoroughly for damage.
- Turn the machine OFF when moving to a new work area. Allow the blades to completely stop rotating before transporting the unit.
- Always use proper care and good judgment when you are confronted with a situation that is not covered in this manual. If you are unsure of what to do, contact your authorized Snow Joe® + Sun Joe® dealer or call the Snow Joe® + Sun Joe® customer service center at 1-866-SNOWJOE (1-866-766-9563).
- Do not use in rain or wet conditions.
- Do not grasp the exposed cutting blades or cutting edges when picking up or holding the appliance.

## Stopping Work

- Always turn the tiller + cultivator OFF and remove the batteries when stopping work or when changing work areas. Never leave the machine running when unattended.
- The blades will continue to rotate for a short period after turning OFF the tiller + cultivator. Wait until the blades have completely stopped before lifting the machine or conducting inspection and maintenance.

- The motor housing remains hot for a short period after the machine is turned OFF. Allow the motor housing to cool completely before touching or storing near combustible material.

## Maintenance + Storage

- Maintain or replace safety and instruction labels.
- Disengage all controls, stop the engine, and wait until the blades come to a complete stop before cleaning, repairing, or inspecting the tiller + cultivator.
- Regularly check the following:
  - i) Blades are clear and can rotate freely** – Accumulation of debris around the blades could impair performance or damage the motor. Inspect and clean the area around the blades before every use.
  - ii) Safety devices are operating properly** – Do not tamper with or adjust safety devices.
  - iii) Bolts and screws are properly tightened** – Visually inspect the machine for any damage and ensure that the tiller + cultivator is in safe working condition.
  - iv) Use only identical replacement parts** – Always replace damaged parts with original equipment manufacturer's (OEM) parts only. Replacement parts that do not meet the original equipment specifications may lead to improper performance and compromise safety.

## Electric Safety

 **WARNING!** Read all safety warnings and instructions. Failure to follow the warnings and instructions may result in electric shock, fire and/or serious injury.

1. Prevent unintentional starting. Ensure the switch is in the off-position before connecting with battery packs, picking up or carrying the appliance. Carrying the appliance with your finger on the switch or energizing appliance that have the switch on invites accidents.
2. Remove the battery packs from the appliance before making any adjustments, changing accessories, or storing appliance. Such preventive safety measures reduce the risk of starting the appliance accidentally.
3. Recharge only with the charger specified by the manufacturer. A charger that is suitable for one type of battery pack may create a risk of fire when used with another battery pack.
4. Use appliances only with specifically designated battery packs. Use of any other battery packs may create a risk of injury and fire.
5. When battery packs are not in use, keep them away from other metal objects, like paper clips, coins, keys, nails, screws or other small metal objects, that can make a connection from one terminal to another. Shorting the battery terminals together may cause burns or a fire.

7. Under abusive conditions, liquid may be ejected from the battery; avoid contact. If contact accidentally occurs, flush with water. If liquid contacts eyes, additionally seek medical help. Liquid ejected from the battery may cause irritation or burns.
8. Do not use a battery pack or appliance that is damaged or modified. Damaged or modified batteries may exhibit unpredictable behavior resulting in fire, explosion or risk of injury.
9. Do not expose a battery pack or appliance to fire or excessive temperature. Exposure to fire or temperature above 265°F (130°C) may cause explosion.
10. Follow all charging instructions and do not charge the battery packs or appliance outside of the temperature range specified in the instructions. Charging improperly or at temperatures outside of the specified range may damage the batteries and increase the risk of fire.
11. Have servicing performed by a qualified repair person using only identical replacement parts. This will ensure that the safety of the product is maintained.
12. Do not modify or attempt to repair the appliance or the battery packs (as applicable) except as indicated in the instructions for use and care.

## Battery + Charger Safety Instructions

We pay a great deal of attention to the design of every battery pack to ensure that we supply you with batteries that are safe, durable and have a high energy density. The battery cells have a wide range of safety devices. Each individual cell is initially formatted and its electrical characteristic curves are recorded. This data is then used exclusively to be able to assemble the best possible battery packs.

Despite all the safety precautions, caution must always be exercised when handling batteries. The following points must be obeyed at all times to ensure safe use. Safe use can only be guaranteed if undamaged cells are used. Incorrect handling of the battery packs can cause cell damage.

**IMPORTANT!** Analyses confirm that incorrect use and poor care of high-performance batteries are the main factors responsible for personal and/or product damage.

 **WARNING!** Use only approved replacement batteries; other batteries may damage the cordless tiller + cultivator and cause it to malfunction, which can lead to serious personal injury.

 **WARNING!** Do not use a battery pack or appliance that is damaged or modified. Damaged or modified batteries may exhibit unpredictable behavior resulting in fire, explosion or risk of injury.

Do not modify or attempt to repair the appliance or the battery packs except as indicated in the instructions for use and care.

Have your battery packs serviced by a qualified repair person using only identical replacement parts. This will ensure that the safety of the battery pack is maintained.

**⚠ CAUTION!** To reduce the risk of injury, charge the iON+ 24V lithium-ion battery packs only in the designated iON+ 24V lithium-ion charger. Other types of chargers present risk of fire, personal injury and damage. Do not wire the battery packs to a power supply plug or car cigarette lighter. Such misuse will permanently disable or damage the battery packs.

- **Avoid dangerous environments** – Do not charge the battery packs in rain, snow or in damp or wet locations. Do not use the battery packs or charger in the presence of explosive atmospheres (gaseous fumes, dust or flammable materials) because sparks may be generated when inserting or removing the battery packs, which could lead to a fire.
- **Charge in a well-ventilated area** – Do not block the charger vents. Keep them clear to allow for proper ventilation. Do not allow smoking or open flames near a charging battery pack. Vented gases may explode.

**NOTE:** The safe temperature range for the battery is 41°F – 105°F (5°C – 40.5°C). Do not charge the battery outside in freezing weather; charge it at room temperature.

- **Maintain charger cord** – When unplugging the charger, pull the plug, not the cord, from the receptacle to reduce the risk of damage to the electrical plug and cord. Never carry the charger by its cord or yank it by the cord to disconnect it from the receptacle. Keep the cord away from heat, oil and sharp edges. Make sure the cord will not be stepped on, tripped over or subjected to damage or stress when the charger is in use. Do not use the charger with a damaged cord or plug. Replace a damaged charger immediately.
- **Do not use an extension cord unless it is absolutely necessary** – Using the wrong, damaged or improperly wired extension cord poses a risk of fire and electric shock. If an extension cord must be used, plug the charger into a properly wired 16 gauge or larger extension cord with the female plug matching the male plug on the charger. Make sure that the extension cord is in good electrical condition.
- **Charger 24VCHRG-DPC is rated for 120 volt AC only** – The charger must be plugged into an appropriate receptacle.
- **Use only recommended attachments** – Use of an attachment not recommended or sold by the battery charger or battery pack manufacturer may result in risk of fire, electric shock or personal injury.
- **Unplug charger when not in use** – Make sure to remove battery packs from unplugged charger.

**⚠ WARNING!** To reduce the risk of electric shock, always unplug the charger before performing any cleaning or maintenance. Do not allow water to flow into the charger. Use a Ground Fault Circuit Interrupter (GFCI) to reduce shock hazards.

- **Do not burn or incinerate battery packs** – Battery packs may explode, causing personal injury or damage. Toxic fumes and materials are created when battery packs are burned.
- **Do not crush, drop or damage battery packs** – Do not use the battery packs or charger if they have sustained a sharp blow, been dropped, run over or have been damaged in any way (i.e. pierced with a nail, hit with a hammer, stepped on, etc.).
- **Do not disassemble** – Incorrect reassembly may pose a serious risk of electric shock, fire or exposure to toxic battery chemicals. If the batteries or charger are damaged, contact an authorized Snow Joe® + Sun Joe® dealer or call the Snow Joe® + Sun Joe® customer service center at 1-866-SNOWJOE (1-866-766-9563) for assistance.
- **Battery chemicals cause serious burns** – Never let a damaged battery pack contact the skin, eyes or mouth. If a damaged battery pack leaks battery chemicals, use rubber or neoprene gloves to safely dispose of it. If skin is exposed to battery fluids, wash the affected area with soap and water and rinse with vinegar. If eyes are exposed to battery chemicals, immediately flush with water for 20 minutes and seek medical attention. Remove and dispose of contaminated clothing.
- **Do not short circuit** – A battery pack will short circuit if a metal object makes a connection between the positive and negative contacts on the battery pack. Do not place a battery pack near anything that may cause a short circuit, such as paper clips, coins, keys, screws, nails and other metallic objects. A short-circuited battery pack poses a risk of fire and severe personal injury.
- **Store your battery packs and charger in a cool, dry place** – Do not store the battery packs or charger where temperatures may exceed 105°F (40.5°C), such as in direct sunlight or inside a vehicle or metal building during the summer.

## Information about the batteries

1. The battery packs supplied with your cordless tiller + cultivator are only partially charged. The battery packs have to be charged completely before you use the tool for the first time.
2. For optimum battery performance, avoid low discharge cycles by charging the battery packs frequently.
3. Store the battery packs in a cool place, ideally at 77°F (25°C) and charged to at least 40%.
4. Lithium-ion batteries are subject to a natural aging process. The battery packs must be replaced at the latest when their capacity falls to just 80% of its capacity when new. Weakened cells in an aged battery pack are no longer capable of meeting the high power requirements needed for the proper operation of your tiller + cultivator, and therefore pose a safety risk.
5. Do not throw battery packs into an open fire as this poses a risk of explosion.
6. Do not ignite the battery packs or expose them to fire.

7. Do not exhaustively discharge batteries. Exhaustive discharge will damage the battery cells. The most common cause of exhaustive discharge is lengthy storage or non-use of partially discharged batteries. Stop working as soon as the performance of the batteries fall noticeably or the electronic protection system triggers. Place the battery packs in storage only after they have been fully charged.
8. Protect batteries and the tool from overloads. Overloads will quickly result in overheating and cell damage inside the battery housing even if this overheating is not apparent externally.
9. Avoid damage and shocks. Immediately replace batteries that have been dropped from a height of more than one meter or those that have been exposed to violent shocks, even if the housing of the battery pack appears to be undamaged. The battery cells inside the battery may have suffered serious damage. In such instances, please read the waste disposal information for proper battery disposal.
10. If the battery pack suffers overloading and overheating, the integrated protective cutoff will switch off the equipment for safety reasons.  
**IMPORTANT!** Do not press the ON/OFF switch any more if the protective cut-off has been activated. This may damage the battery packs.
11. Use only original battery packs. The use of other batteries poses a fire risk and may result in injuries or an explosion.

## Information about the charger and the charging process

1. Please check the data marked on the rating plate of the battery charger. Be sure to connect the battery charger to a power supply with the voltage marked on the rating plate. Never connect it to a different mains voltage.
2. Protect the battery charger and its cord from damage. Keep the charger and its cord away from heat, oil and sharp edges. Have damaged cords repaired without delay by a qualified technician at an authorized Snow Joe® + Sun Joe® dealer or call the Snow Joe® + Sun Joe® customer service center at 1-866-SNOWJOE (1-866-766-9563).
3. Electrical plugs must match the outlet. Never modify the plug in any way. Do not use any adapter plugs with grounded appliances. Unmodified plugs and matching outlets will reduce the risk of electric shock.
4. Keep the battery charger, battery packs and the cordless tool out of the reach of children.
5. Do not use the supplied battery charger to charge other cordless tools.
6. During periods of heavy use, the battery packs will become warm. Allow the battery packs to cool to room temperature before inserting them into the charger to recharge.
7. Do not overcharge batteries. Do not exceed the maximum charging times. These charging times only apply to discharged batteries. Frequent connection of a charged or

partially charged battery pack will result in overcharging and cell damage. Do not leave batteries inside the charger for days on end.













8. Never use or charge battery if you suspect that it has been more than 12 months since the last time they were charged. There is a high probability that the battery pack has already suffered dangerous damage (exhaustive discharge).
9. Charging batteries at a temperature below 41°F (5°C) will cause chemical damage to the cells and may cause a fire.
10. Do not use batteries that have been exposed to heat during the charging process, as the battery cells may have suffered dangerous damage.
11. Do not use batteries that have suffered curvature or deformation during the charging process or those that exhibit other atypical symptoms (gassing, hissing, cracking, etc.).
12. Never fully discharge the battery packs (maximum recommended depth of discharge is 80%). A complete discharge of the battery packs will lead to premature aging of the battery cells.

## Protection from environmental influences

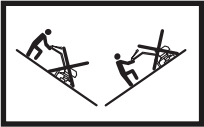
1. Wear suitable work clothes. Wear safety goggles.
2. Protect your cordless tool and the battery charger from moisture and rain. Moisture and rain can cause dangerous cell damage.
3. Do not use the cordless tool or the battery charger near vapors and flammable liquids.
4. Use the battery charger and cordless tools only in dry conditions and at an ambient temperature of 41°F – 105°F (5°C – 40.5°C).
5. Do not keep the battery charger in places where the temperature is liable to reach over 105°F (40.5°C). In particular, do not leave the battery charger in a car that is parked in the sunshine.
6. Protect batteries from overheating. Overloads, overcharging and exposure to direct sunlight will result in overheating and cell damage. Never charge or work with batteries that have been overheated – replace them immediately, if possible.
7. Store the charger and your cordless tool only in dry locations with an ambient temperature of 41°F – 105°F (5°C – 40.5°C). Store your lithium-ion battery packs in a cool, dry place at a temperature of 77°F (25°C). Protect the battery packs, charger and cordless tool from humidity and direct sunlight. Only place fully charged batteries in storage (charged to at least 40%).
8. Prevent the lithium-ion battery packs from freezing. Battery packs that were stored below 32°F (0°C) for more than 60 minutes must be discarded.
9. When handling batteries, be wary of electrostatic charge. Electrostatic discharges can damage the electronic protection system and the battery cells. Avoid electrostatic charging and never touch the battery poles.

# Safety Symbols

The following table depicts and describes safety symbols that may appear on this product. Read, understand and follow all instructions on the machine before attempting to assemble and operate.

Symbols	Descriptions	Symbols	Descriptions
	<b>READ THE OPERATOR'S MANUAL(S)</b> – Read, understand, and follow all instructions in the user manual(s) before attempting to assemble and operate.		Wear eye protection, breathing protection, and ear protection (i.e. safety goggles, dust masks, and ear defenders).
	<b>SAFETY ALERT</b> – Indicates a precaution, a warning, or a danger.		<b>WARNING!</b> Do not expose the unit to rain or wet conditions.
	Beware of foreign objects that could be thrown from the appliance. Keep bystanders a safe distance away from the work area.		<b>WARNING!</b> Rotating parts may cause serious injury. Make sure the blades come to a complete stop before transporting the machine or before inspecting, cleaning, or conducting any other maintenance.
	Work across slopes; never work up and down such surfaces.		Inspect the work area prior to use and remove all objects that could be thrown by the appliance. If a hidden object is discovered while working, stop the engine and remove the object.
	Wear safety gloves during use to protect hands.		Wear safety footwear at all times to provide protection against objects that may accidentally fall on feet.
	The rotating part will continuously run for several seconds after you turn off the machine.		Indoor use only. Only use battery charger indoors.

# Know Your Cordless Tiller + Cultivator

Read the owner's manual and safety rules carefully before operating your cordless tiller + cultivator. Compare the illustration below to the actual unit in order to familiarize yourself with the location of the various controls and adjustments. Save this manual for future reference.

1. Safety lock button
2. ON/OFF switch
3. Right upper handle
4. Left upper handle
5. Upper handle frame
6. Cable clip (2)
7. Middle handle frame
8. Middle handle knob + bolt (2)
9. Lower handle frame
10. Lower handle knob + bolt (2)
11. Motor housing
12. Battery compartment cover
13. Battery compartment
14. Tiller blades
15. Wheel (2)
16. Wheel adjustment knob
17. Battery indicator
18. Push button for battery indicator
19. Push lock button
20. iON+ 24V lithium-ion battery (24VBAT-LTE) featuring exclusive EcoSharp® technology (2)
21. iON+ 24V lithium-ion dual-port charger (24VCHRG-DPC)
22. Charger plug

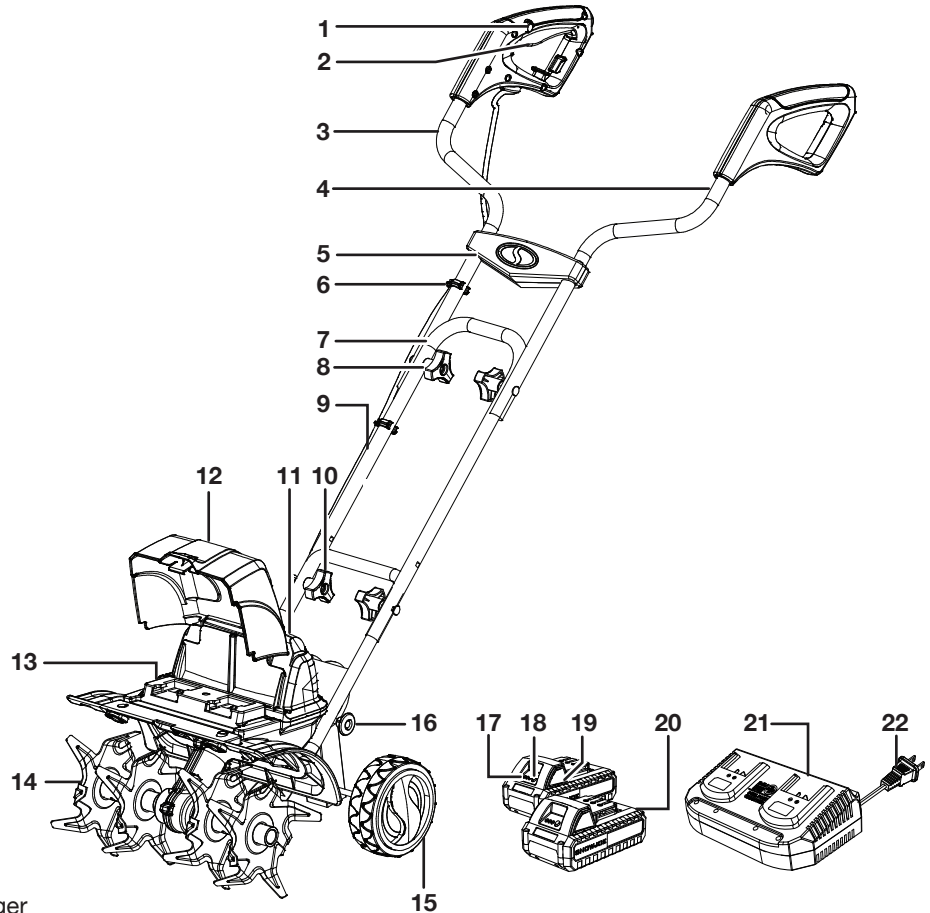

## Technical Data

Motor .....	500 W Brushless	Cultivating Width Max .....	14 in. (36 cm)
Battery Voltage Max* .....	48V D.C. (2 x 24V)	Cultivating Depth Max .....	7 in. (18 cm)
Battery Capacity .....	2.0 Ah each	Blade .....	4 steel 7 in. (18 cm) tilling blades
Battery Runtime Max .....	13 min (excavates up to 270 sq ft of 4 in. dirt)	No Load Speed .....	180 rpm
Charger Input .....	120V AC, 60 Hz, 160 W	Height Adjustment .....	3 positions
Charger Output .....	26V DC, 2.2 A (2 port)	Weight (tiller + cultivator alone) .....	23.4 lbs (10.6 kg)
Charge Time Max .....	55 min	Weight (with batteries installed) .....	26.7 lbs (12.1 kg)

\*Generates 48V max with two 24V lithium-ion batteries. Initial no-load voltage, per fully charged battery, peaks at 24V. Nominal voltage under typical load is 21.6V.

# Unpacking

## Carton Contents

- Cordless tiller + cultivator with lower handle frame
- Middle handle frame
- Left upper handle
- Right upper handle
- Upper Handle frame
- Handle knobs + bolts (4 sets)
- Cable clips (2)
- iON+ 24V lithium-ion batteries (2)
- iON+ 24V lithium-ion dual-port battery charger
- Manuals with registration card

1. Carefully remove the cordless tiller + cultivator and check to see that all of the above items are supplied.
2. Inspect the product carefully to make sure no breakage or damage occurred during shipping. If you find damaged or missing parts, DO NOT return the unit to the store. Please call the Snow Joe® + Sun Joe® customer service center at 1-866-SNOWJOE (1-866-766-9563).

**NOTE:** Do not discard the shipping carton and packaging material until you are ready to use your new cordless tiller + cultivator. The packaging is made of recyclable materials. Properly dispose of these materials in accordance with local regulations.

**IMPORTANT!** The equipment and packaging material are not toys. Do not let children play with plastic bags, foils or small parts. These items can be swallowed and pose a suffocation risk!

## Battery Pack Operation

The equipment is powered by two lithium-ion batteries. The battery packs are completely sealed and maintenance free.





**⚠️ WARNING!** The cordless tiller + cultivator can only be powered by both of the batteries together. One battery cannot provide sufficient power to the tool. Make sure to use two batteries of the same voltage and the same capacity. Using the tool with batteries of different capacity will cause damage to the batteries.

**⚠️ WARNING!** Before first use, the batteries require 55 min charge time to be fully charged. When the batteries are at low capacity, recharge for 55 min again before resuming operation.

## Battery Charge Level Indicator

The battery packs are equipped with a push button for checking the charge level. Simply press the push button to read off the battery charge level from the LEDs of the battery indicator:

- All 3 level monitoring LEDs are lit: Battery charge level is high.
- 2 level monitoring LEDs are lit: Battery charge level is decreasing. Stop work as soon as possible.
- 1 level monitoring LED is lit: Battery is flat. Stop work IMMEDIATELY and charge the battery. Otherwise the battery's service life will be greatly shortened.

Lights	Light Indicators
	Charge level button
	The battery is at 30% capacity and requires charging
	The battery is at 60% capacity and requires charging soon
	The battery is at full capacity

**NOTE:** If the charge level button does not appear to be working, connect the battery to the charger and charge as needed.

**NOTE:** Immediately after using the battery pack, the charge level button may display a lower charge than it will if checked a few minutes later. The battery cells "recover" some of their charge after resting.

## Charger Operation

**⚠️ WARNING!** Charge only iON+ 24V lithium-ion battery packs with their compatible iON+ 24V lithium-ion charger. Other types of batteries may cause personal injury and damage.

To reduce the risk of electric shock, do not allow water to flow into the charger's AC/DC plug.

## When to Charge the iON+ 24VBAT-LTE Lithium-Ion Batteries

**NOTE:** The iON+ 24VBAT-LTE lithium-ion battery packs do not develop a "memory" when charged after only a partial discharge. Therefore, it is not necessary to run down the battery packs before placing them into the charger.



- Use the battery charge indicator lights to determine when to charge your iON+ 24VBAT-LTE lithium-ion battery packs.
- You can "top-off" your battery packs' charge before starting a big job or after a long day of use.

## Charging the Batteries

1. Open the battery compartment cover to expose the battery packs inside. Press the push lock buttons on the batteries to pull the battery packs out of the equipment (Fig. 1).

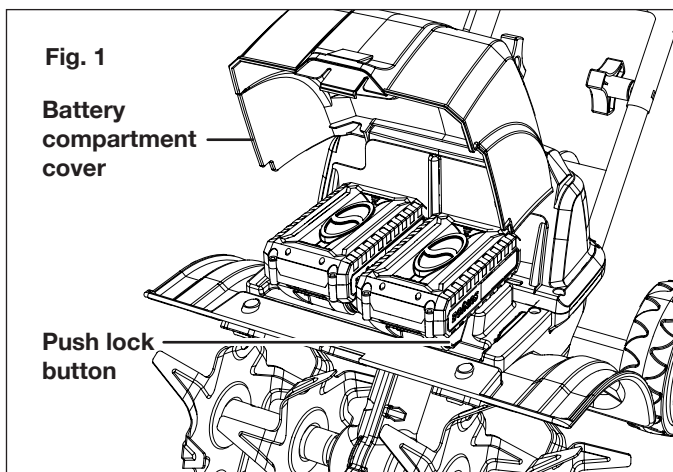

2. Check that the mains voltage is the same as that marked on the rating plate of the battery charger. Then, insert the charger's plug into the electrical wall outlet. When you plug in the charger, two green lights will illuminate and stay green (Fig. 2).

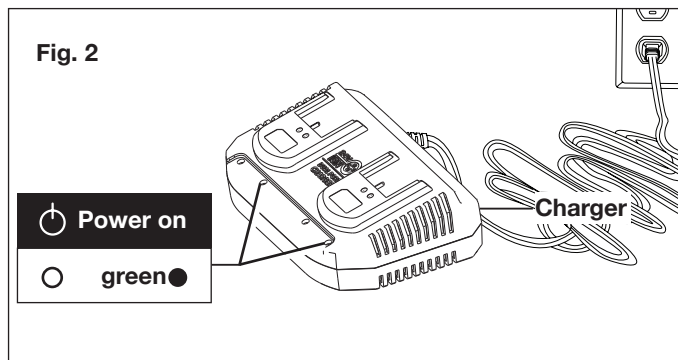

3. Place the battery packs into the charger by sliding the packs to lock them into position. When you insert the batteries into the charger, the two green lights will go off, and the red lights will illuminate to indicate that the batteries are charging (Fig. 3).

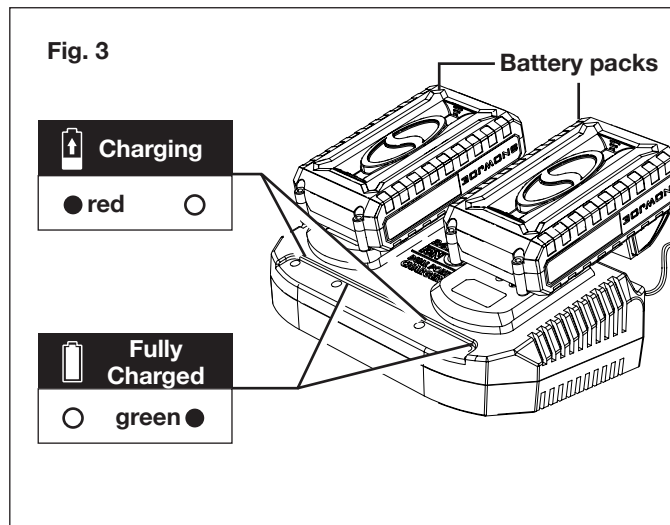

4. When the charger lights turn green, the batteries are fully charged (Fig. 3).

**NOTE:** A fully discharged pack with an internal temperature in the normal range will fully charge in 55 min (between 32°F/0°C and 113°F/45°C).

5. If the light indicators do not come on at all, check that the battery packs are fully seated into the bay. Remove the battery packs and reinsert. If the problem persists, contact an authorized Snow Joe® + Sun Joe® dealer or call the Snow Joe® + Sun Joe® customer service center at 1-866-SNOWJOE (1-866-766-9563) for assistance.
6. When charging is complete, remove the batteries from the charger by pressing the push lock buttons and sliding the batteries backward to unlock them from the charger (Fig. 4).

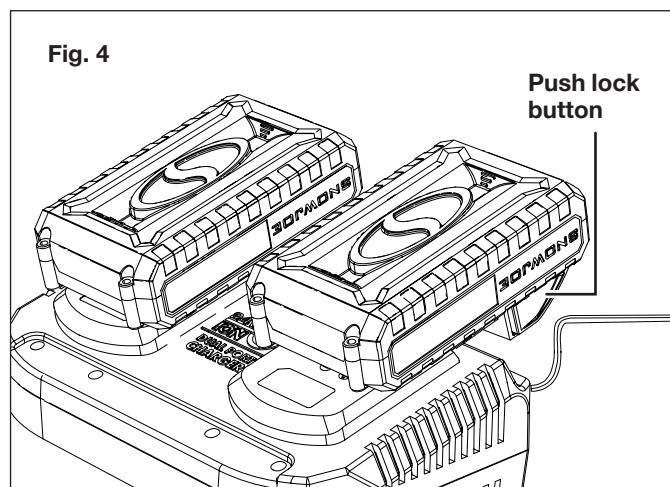

**CAUTION!** FIRE HAZARD. When remove the batteries from the charger, be sure to unplug the charger from the outlet first, then remove the batteries from the charger.

**WARNING!** This charger does not automatically turn off when the batteries are fully charged. Please take care not to leave the batteries in the charger. Switch off or unplug the charger at the mains when charging is complete.

- Timely recharging of the batteries will help prolong the batteries' life. You must recharge the battery packs when you notice a drop in the equipment's power.

**IMPORTANT!** Never allow the battery packs to become fully discharged as this will cause irreversible damage to the batteries.

## Charging a Hot or Cold Battery Pack

The green indicator lights on the charger base indicates that the battery packs' temperatures are outside the charging range. Once the packs are within the acceptable range, normal charging will take place and the red light will be continuous. Hot or cold battery packs may take longer to charge.

## Assembly

### Upper Handles Assembly

- Separate the upper handle frame by removing the 4 screws. Retain the screws (Fig. 5).

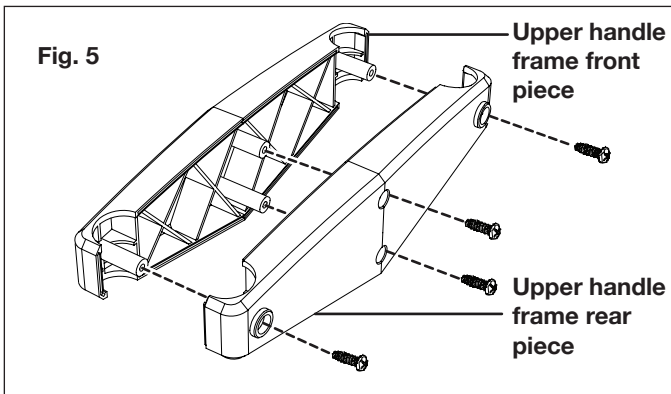

- Fit the left upper handle and the right upper handle in the handle grooves of the upper handle frame rear piece. Make sure the holes are aligned (Fig. 6).

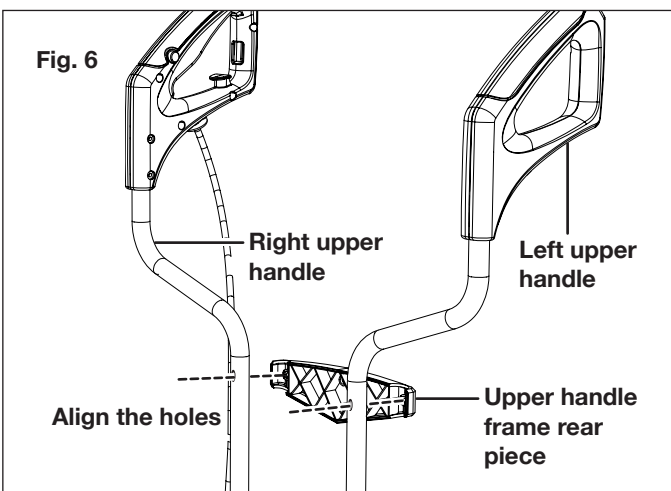

- Put the handle frame front piece in place, inserting the 4 pegs into the holes on the handle frame rear piece (Fig. 7).

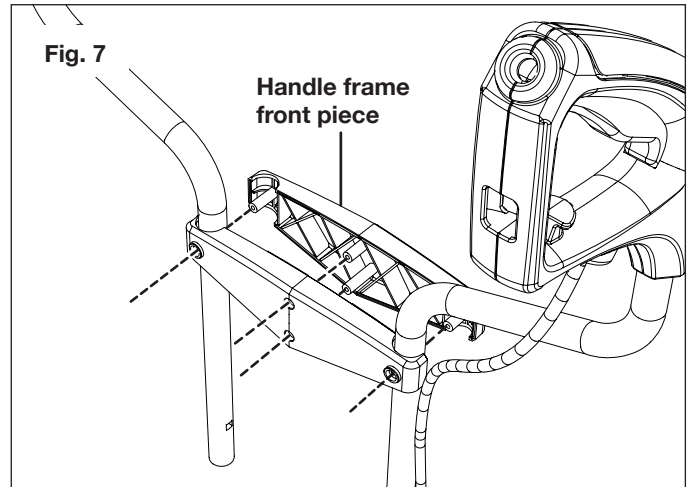

- Join the assembly with the original 4 screws, as shown (Fig. 8).

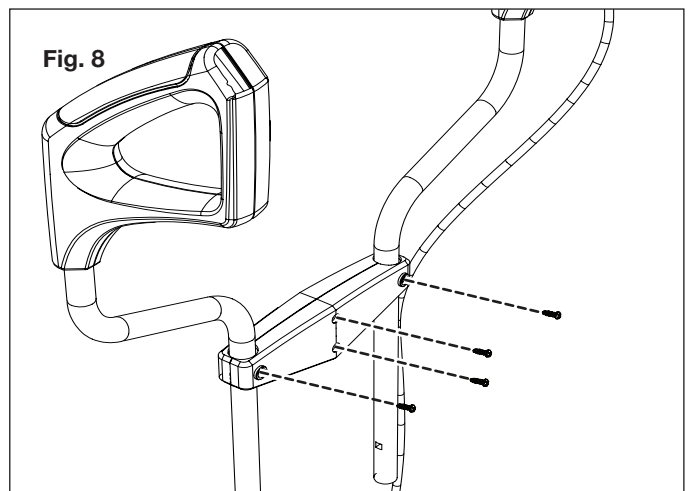

### Connect Handle Frames

- Connect the upper handle frame assembly to the middle handle frame by 2 sets of handle knobs + bolts, as shown (Fig. 9).

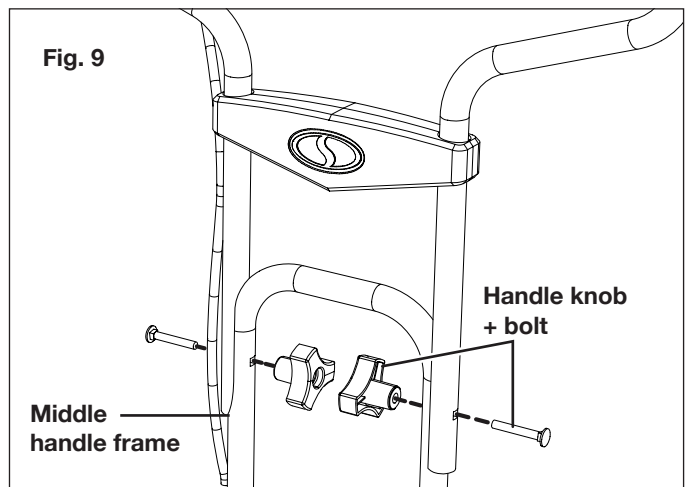

2. Connect the upper handle frame + middle handle frame to the lower handle frame by the other 2 sets of handle knobs + bolts, as shown (Fig. 10).

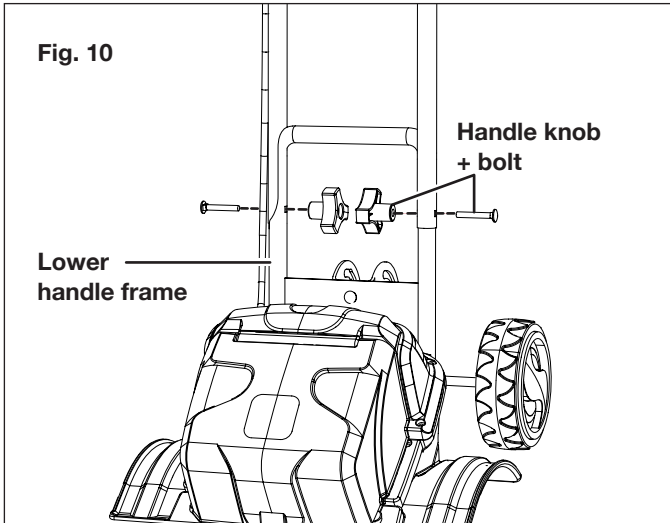

**NOTE:** Make sure that the handle knobs are placed inside the handle frame. Otherwise they will affect the wheel adjustment system.

3. Clip on the cable clips to secure the cable.

## Operation

### Intended Use

The 24V-X2-TLR14 cordless tiller + cultivator is designed for small gardens and flower beds, this cordless tiller + cultivator effectively loosens and turns over new soil. It may also be used to mix coarse soil with fertilizer, peat, and compost. This product may not be used to till extremely dry or wet soil.

The use of this product in rain or wet conditions is prohibited.

For safety reasons, it is essential to read the entire instruction manual before first use and to observe all the instructions contained within this manual.

This product is intended for private domestic use only. It is not intended for any commercial trade use. It must not be used for any purposes other than those described.

### Wheel Adjustment

**⚠️ WARNING!** Always switch the product off and remove the batteries before making any adjustments.

1. The wheels can be adjusted to 3 different positions for better cultivating results (Fig. 11).

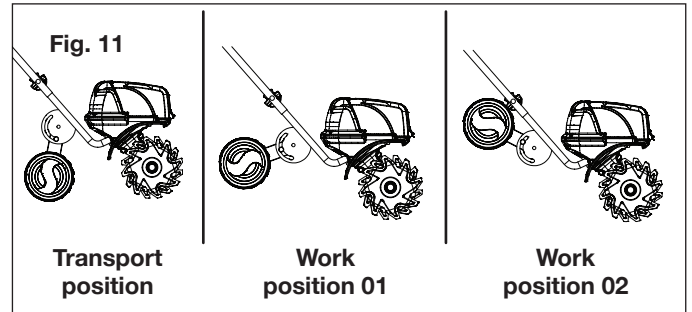

2. To adjust the wheel position, push the wheel adjustment knob while moving it to the slot for desired position; let go of the knob and make sure it locks into position (Fig. 12).

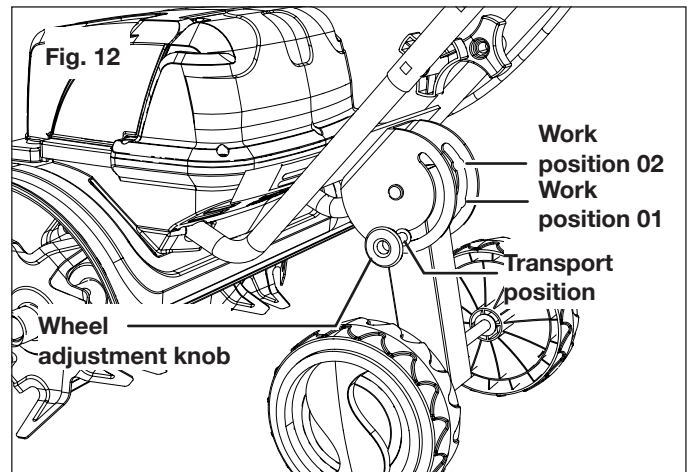

### Starting the Machine

**⚠️ WARNING!** Rotating blades may cause serious injury. The blades will continue to turn for a few seconds after the tool has been switched OFF. Do not touch the rotating blades. Contact with hot components (i.e. motor housing, gear box, etc.) on the machine may cause burns. Allow the machine to cool before handling.

1. Open the battery compartment cover and slide both batteries in until they click to lock it into position, then close the battery compartment cover (Fig. 13).

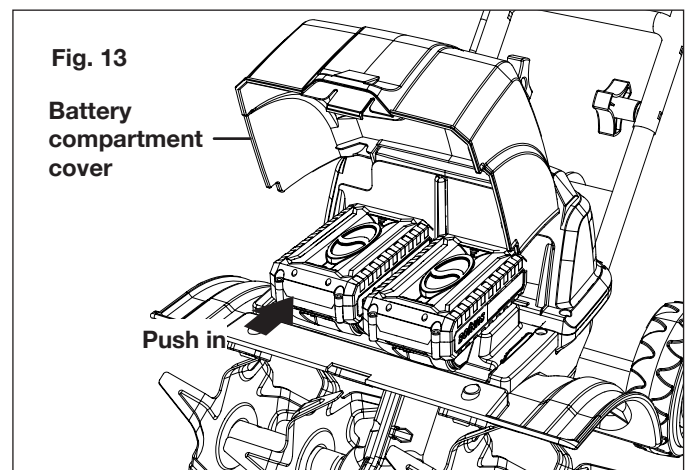

2. To turn the tool ON, press and hold the safety lock button while squeezing the ON/OFF switch. Once the tool is running, release the safety lock button (Fig. 14).

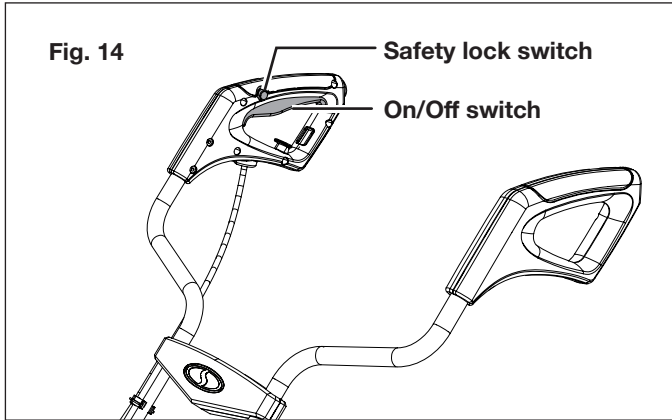

3. To switch OFF, release the ON/OFF switch (Fig. 14).

## Operating Tips

- Before each use, check the product, the batteries, and any other accessories for damage. Do not use the product if it is damaged or shows wear.
- Double check that the accessories and attachments are properly fitted.
- Always hold the product by its handles. Keep the handles dry to ensure a secure grip.
- Ensure that the air vents are always unobstructed and clear. Clean them if necessary with a soft brush. Blocked air vents may lead to overheating and damage the product.
- Switch the product off immediately if you are disturbed while working by other people entering the working area. Always let the product come to a complete stop before averting your attention.
- Do not overwork yourself. Take regular breaks to ensure you can concentrate on the task at hand and have full control over the product.

**⚠ WARNING!** In some countries, regulations define restrictions for use of such products, including the times and days when operation is permissible. Ask your community for detailed information and observe these regulations in order to preserve a peaceful neighborhood and avoid violating any local ordinances.

## Tilling

- Make sure that the work area is clear of stones, sticks, wire, or other objects that could damage the product or its motor.
- Do not till very wet soil because wet soil tends to stick to the working tool, preventing proper blade rotation; it could also cause you to slip and fall.
- Always maintain a firm grip on the product. For better guidance, apply light pressure to the handles.

**⚠ WARNING!** Do not place hands, feet, or any other part of the body or clothing near the rotating blades or any other moving part. The blades begin to rotate forward once the trigger switch is depressed. The blades continue to rotate until the trigger switch is released. Failure to avoid contact with the rotating blades could cause serious personal injury.

- Do not try to till too deeply or force the product into soil that is extremely hard or resistant.
- Walk the product through the soil at a normal pace and in as straight a line as possible.
- Till in slightly overlapping rows. To till most effectively, follow the pattern indicated in Fig. 15. Start by moving the tiller + cultivator up and down in vertical lines, then work horizontally from left to right. This will keep the rows even and ensure that all the ground is tilled without missing any spots.

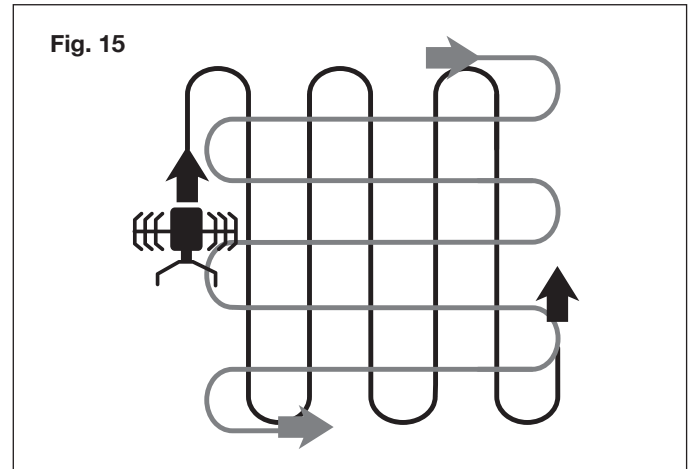

- Pay special attention when changing direction. Apply light pressure to the handle in order to lift the blades and facilitate the turn. Turn the product around using the wheels as a guide. Gradually release pressure on the handle and move the blades back to the ground.

**⚠ WARNING!** Stop the motor if the product strikes a foreign object. Switch the product off, remove the batteries, and let it cool completely. Inspect the product thoroughly for damage and have any damage repaired before restarting.

Extensive vibration of the product during operation is an indication of damage. Immediately stop the motor and promptly inspect and repair the tool.

## After Use

- Switch the product off, remove the batteries, and let it cool completely.
- Check, clean, and store the product as described below.

# Care + Maintenance

## The Golden Rules for Care

**⚠️ WARNING!** Always switch the product off, remove the batteries, and let the product cool completely before inspecting, cleaning, or performing any other maintenance task.

- Keep the product clean. Remove any debris after each use and before storage.
- Regular and proper cleaning will help ensure safe use and prolong the life of the product.
- Inspect the product before each use for worn and damaged parts. If you find broken and/or worn parts, do not use the tool.

**⚠️ WARNING!** Only perform the repairs and maintenance work described in this manual. Any other work must be performed by a qualified technician.

## General Cleaning

- Clean the product with a dry cloth. Use a brush for areas that are hard to reach.
- Be sure to clean the air vents after every use with a cloth and brush.
- Remove stubborn dirt with high pressure air (max. 3 bar).

**NOTE:** Do not use chemical, alkaline, abrasive, or other aggressive detergents or disinfectants to clean this product as such substances might damage the tool's surfaces.

- Check for worn or damaged parts. Replace worn parts as necessary or contact the Snow Joe® + Sun Joe® customer service center at 1-866-SNOWJOE (1-866-766-9563) for repair before using the product again.

## Cleaning the Underbody + Working Tool

**⚠️ WARNING!** Wear safety gloves when working on or near the working tool. Use appropriate tools (e.g a wooden stick) when necessary; never use your bare hands!

- Keep the underbody and blades clean and free of debris. Use a brush or another implement to remove soil from the working tool.
- All nuts and bolts must be checked periodically for tightness before operation. After prolonged use, especially in sandy soil conditions, the working tool will become worn and lose some of its original shape. Tilling efficiency will be reduced and the working tool should be replaced.
- Have worn or damaged working parts replaced with new ones of the same type by a qualified technician.
- To prolong the life span of the working tool and the product, lubricate the blades after each use.

**⚠️ WARNING!** Unexpected blade movement may cause personal injury. Before servicing, repairing, or inspecting the unit, turn the motor OFF and remove the batteries. Wait for the blades to completely stop rotating before conducting inspection, cleaning, or maintenance.

Before and after each use, check the product and accessories (or attachments) for wear and damage. When necessary, only use identical replacement parts that are approved by the manufacturer.

**⚠️ WARNING!** Contact with hot components (e.g. motor housing, gear box, etc.) on the machine may cause burns. Allow the machine to cool off before handling.

## IMPORTANT!

- Wear protective gloves when cleaning or maintaining the machine.
- Do not use cleaning fluids or solvents or spray the machine down with water (especially water under pressure) when cleaning the machine.

**NOTE:** After each use, follow these steps to properly clean the unit:

1. Remove soil, dirt, and foliage stuck in the blades, drive shaft, tool surface, and vents with a brush or dry cloth.
2. Spray or rub biodegradable oil onto the blades.
3. Clean soiled grips with a damp cloth.

Always inspect the machine for damaged and worn parts after each use. Check that safety features (i.e. labels, guards, etc.) are in place. Check that nuts, bolts, and screws are tight.

## Changing the Blades

**NOTE:** The machine is fitted with four tilling blades that can easily be changed in pairs. Both of the steel blade pairs can be fitted on the left or right, as required. Always change both blade pairs at the same time to avoid imbalance and damage to the machine.

To replace the blades, follow the steps below:

1. While standing on a flat and stable surface, switch off the unit and remove the batteries.
2. Remove the hex bolts and the self-locking nuts, then remove the steel blades (Fig. 16).

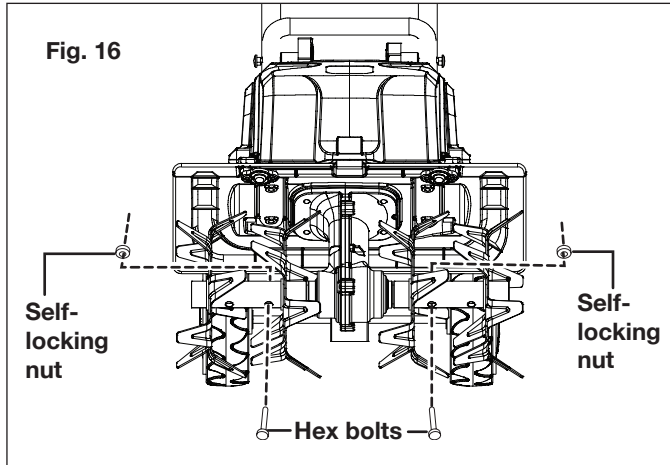

3. Clean the drive shaft with biodegradable oil (Fig. 17).
4. Place the new blades onto the drive shaft so that the holes on the axles line up with the holes on the drive shaft (Fig. 17).

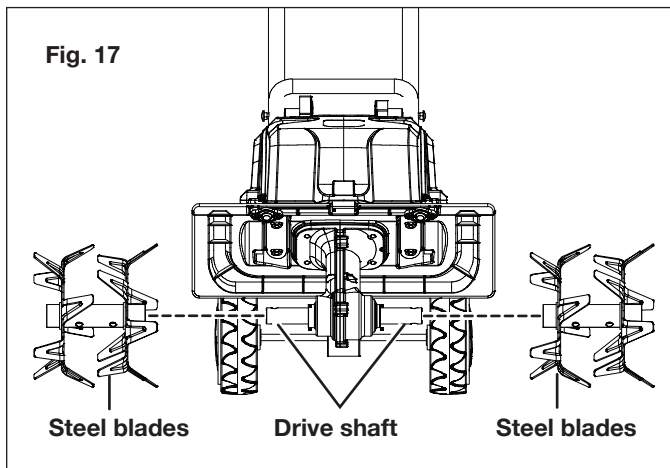

5. Insert the hex bolts through the holes and secure them with the self-locking nuts (Fig. 16).

**IMPORTANT:** The blades must be set in the correct turning direction. Note the way the old blades came off and replace the new ones exactly the same way.

## Transportation

- Switch the product off. Ensure that the wheels are set to the transport position (see Fig. 11, pg. 11).
- Always carry the product by its transport handles.
- If you are transporting the tiller + cultivator in a vehicle, brace it properly to protect it from heavy impact or strong vibrations.
- Secure the product to prevent it from falling over or slipping.

## Repair

This product does not contain any parts that can be repaired by the consumer. Contact an authorized Snow Joe® + Sun Joe® dealer or call the Snow Joe® + Sun Joe® customer service center at 1-866-SNOWJOE (1-866-766-9563) for assistance.

## Storage

- Examine the cordless tiller + cultivator thoroughly for worn, loose, or damaged parts. Should you need to repair or replace a part, contact an authorized Snow Joe® + Sun Joe® dealer or call the Snow Joe® + Sun Joe® customer service center at 1-866-SNOWJOE (1-866-766-9563) for assistance.
- Remove the batteries from the cordless tiller + cultivator before storing.
- Clean the product as described above.
- Store the product and its accessories in a dark, dry, frost-free, and well-ventilated place.
- Always store the product in a place that is inaccessible to children.
- The ideal storage temperature is between 50°F (10°C) and 86°F (30°C).
- We recommend using the original package for storage or covering the product with a suitable cover or enclosure to protect it against dust.

## Battery + Charger Off-Season Storage

1. Do not expose your battery packs or charger to water, rain or allow them to get wet. This could permanently damage the charger and the battery pack. Do not use oil or solvents to clean or lubricate your battery packs as the plastic casing can become brittle and crack, causing a serious risk of injury.
2. Store the battery packs and charger at room temperature away from moisture. Do not store in damp locations where corrosion of terminals may occur. As with other battery pack types, permanent capacity loss can result if the pack is stored for long periods of time at high temperatures (over 120°F/49°C).
3. iON+ 24VBAT-LTE lithium-ion battery packs maintain their charge during storage longer than other battery pack types. As a general practice, it is best to unplug the battery charger and remove the battery packs when they are not in use. Recharge the battery packs every 6 months to 60% capacity (2 lights on) during off-season storage to maintain optimal battery performance.



## Recycling + Disposal

The product comes in a package that protects it against damage during shipping. Keep the package until you are sure that all parts have been delivered and the product is functioning properly. Recycle the package afterwards or keep it for long-term storage.

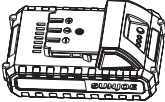
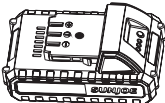
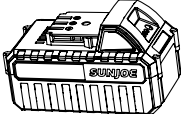
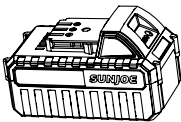

# Optional Accessories

**⚠️WARNING!** ALWAYS use only authorized Snow Joe® + Sun Joe® replacement parts and accessories. NEVER use replacement parts or accessories that are not intended for use with this cordless tiller + cultivator. Contact Snow Joe® + Sun Joe® if you are unsure whether it is safe to use a particular replacement part or accessory with your cordless tiller + cultivator. The use of any other attachment or accessory can be dangerous and could cause injury or mechanical damage.

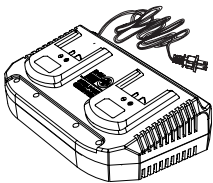
Accessories	Item	Model
	iON+ 24V 2.0 Ah Lithium-Ion Battery <i>Battery Charge Time Max:</i> 24VCHRG-QC: 55 min   24VCHRG-DPC: 55 min <i>Battery Runtime Max:</i> 13 min (excavates up to 270 sq ft of 4 in. dirt)	24VBAT-LTE
	iON+ 24V 2.5 Ah Lithium-Ion Battery <i>Battery Charge Time Max:</i> 24VCHRG-QC: 1 hr 10 min   24VCHRG-DPC: 1 hr 10 min <i>Battery Runtime Max:</i> 16 min (excavates up to 345 sq ft of 4 in. dirt)	24VBAT-LT
	iON+ 24V 4.0 Ah Lithium-Ion Battery <i>Battery Charge Time Max:</i> 24VCHRG-QC: 1 hr 50 min   24VCHRG-DPC: 1 hr 50 min <i>Battery Runtime Max:</i> 25 min (excavates up to 540 sq ft of 4 in. dirt)	24VBAT
	iON+ 24V 5.0 Ah Lithium-Ion Battery <i>Battery Charge Time Max:</i> 24VCHRG-QC: 2 hr 20 min   24VCHRG-DPC: 2 hr 20 min <i>Battery Runtime Max:</i> 31 min (excavates up to 680 sq ft of 4 in. dirt)	24VBAT-XR
	iON+ 24V Lithium-Ion Battery Quick Charger	24VCHRG-QC
	iON+ 24V Lithium-Ion Dual-Port Battery Charger	24VCHRG-DPC

**NOTE:** Accessories are subject to change without any obligation on the part of Snow Joe® + Sun Joe®. Accessories can be ordered online at [sunjoe.com](http://sunjoe.com) or via phone by contacting the Snow Joe® + Sun Joe® customer service center at 1-866-SNOWJOE (1-866-766-9563).









## SNOW JOE® + SUN JOE® CUSTOMER PROMISE

**ABOVE ALL ELSE**, Snow Joe, LLC (“Snow Joe”) is dedicated to you, our customer. We strive to make your experience as pleasant as possible. Unfortunately, there are times when a Snow Joe®, Sun Joe®, or Aqua Joe® product (“Product”) does not work or breaks under normal operating conditions. We think it’s important that you know what you can expect from us. That’s why we have a Limited Warranty (“Warranty”) for our Products.

---

### **OUR WARRANTY:**

Snow Joe warrants new, genuine, powered and non-powered Products to be free from defects in material or workmanship when used for ordinary household use for a period of two years from the date of purchase by the original, end-user purchaser when purchased from Snow Joe or from one of Snow Joe’s authorized sellers with proof of purchase. Because Snow Joe is unable to control the quality of its Products sold by unauthorized sellers, unless otherwise prohibited by law, this Warranty does not cover Products purchased from unauthorized sellers. If your Product does not work or there’s an issue with a specific part that is covered by the terms of this Warranty, Snow Joe will elect to either (1) send you a free replacement part, (2) replace the Product with a new or comparable product at no charge, or (3) repair the Product. How cool is that!

**This Warranty gives you specific legal rights, and you may also have other rights which vary from State to State.**

### **PRODUCT REGISTRATION:**

Snow Joe strongly encourages you to register your Product. You can register online at [snowjoe.com/register](https://snowjoe.com/register), or by printing and mailing in a registration card available online from our website, or calling our Customer Service Department at **1-866-SNOWJOE (1-866-766-9563)**, or by e-mailing us at [help@snowjoe.com](mailto:help@snowjoe.com). Failure to register your Product will not diminish your warranty rights. However, registering your Product will allow Snow Joe to better serve you with any of your customer service needs.

### **WHO CAN SEEK LIMITED WARRANTY COVERAGE:**

This Warranty is extended by Snow Joe to the original purchaser and original owner of the Product.

### **WHAT IS NOT COVERED?**

This Warranty does not apply if the Product has been used commercially or for non-household or rental applications. This Warranty also does not apply if the Product was purchased from an unauthorized seller. This Warranty also does not cover cosmetic changes that do not affect performance. Wearing parts like belts, augers, chains and tines are not covered under this Warranty, and can be purchased at [snowjoe.com](https://snowjoe.com) or by calling **1-866-SNOWJOE (1-866-766-9563)**.



[sunjoe.com](http://sunjoe.com)